

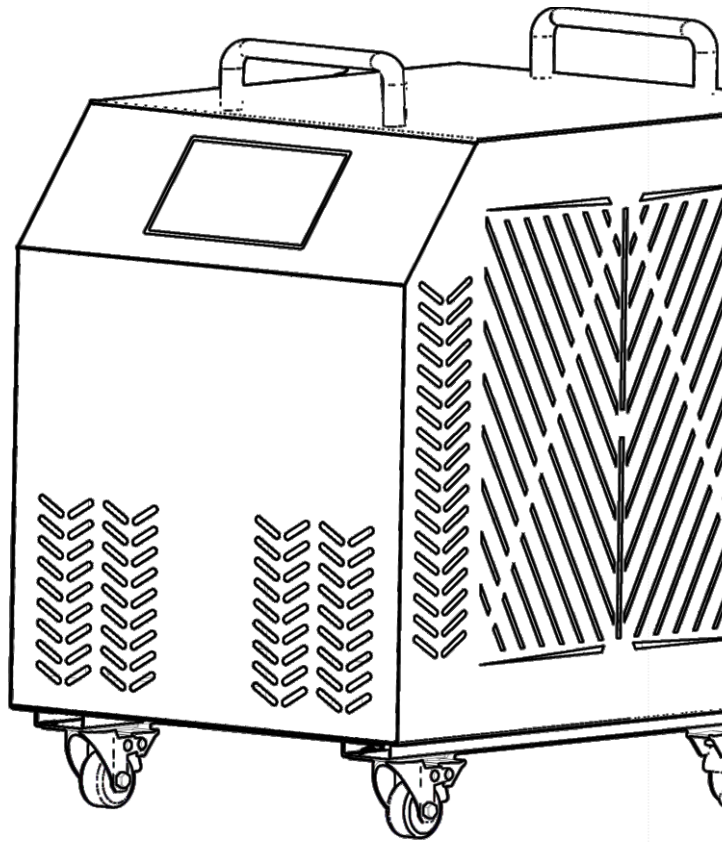

ICE BATH CHILLER

USER MANUAL



CAUTION

1. Operators must be 18 years or older.
 2. Avoid using the chiller with wet hands.
 3. Keep the power cord away from heavy objects and do not run it under carpets.
 4. Do not insert objects into the chiller's vents or openings.
 5. Exercise caution around children, the elderly, and those with mobility issues.
 6. Always keep the chiller upright and on stable, level surface; do not invert.
 7. Install the chiller in well-ventilated areas(at least 100cm of clear space around vents for airflow), avoiding closets or cabinets and keeping vents clear of obstructions.
 8. Do not disassemble or modify the chiller.
 9. Avoid using in very humid or dusty conditions.
 10. For electrical issues, contact authorized service personnel.
 11. Keep pets and children away during operation.
 12. Report any sign of damage, leaking, strange noises, smells, or performance issues immediately.
 13. Disconnect power before maintenance or cleaning.
 14. Avoid placing the chiller in direct sunlight or near heat sources.
 15. Ensure the filter is installed when the chiller is working.
 16. Regularly clean the water filter and dust net for optimal efficiency.
 17. If the ambient temperature drops to 0 °C(32°F), disconnect the pipes and open the drainer to **FULLY** drain all water from the chiller to prevent freezing damage.
- Working Temperature: 1°C-45°C (34°F -113°F)
 - Storage Temperature(No water inside the chiller): -20°C-55°C (-4°F -131°F)
 - Storage Relative Humidity: 20%-85%

 **Electricity** is very dangerous, in order to prevent accidents or death please pay attention to safety.

- During and after transportation, the chiller must stay upright on a stable surface at all times.
- After transportation, and before use, the chiller must be left for 24hrs for the refrigeration gas to settle.
- Make sure the chiller is plugged into an Ac socket or extension cable that is suitable for use.
- Ensure the chiller is kept dry at all times, do not immerse, splash or spray the unit with water. If the unit does get wet, unplug it immediately and do not use.
- Never leave the chiller switched on when staying in the water, always ensure the unit is switched off during your cold water therapy session.
- If the chiller stops working or doesn't work when switched on, unplug it immediately and do not use.
- We accept no responsibility for misuse or failure to use this equipment safely as instructed

COMPONENTS

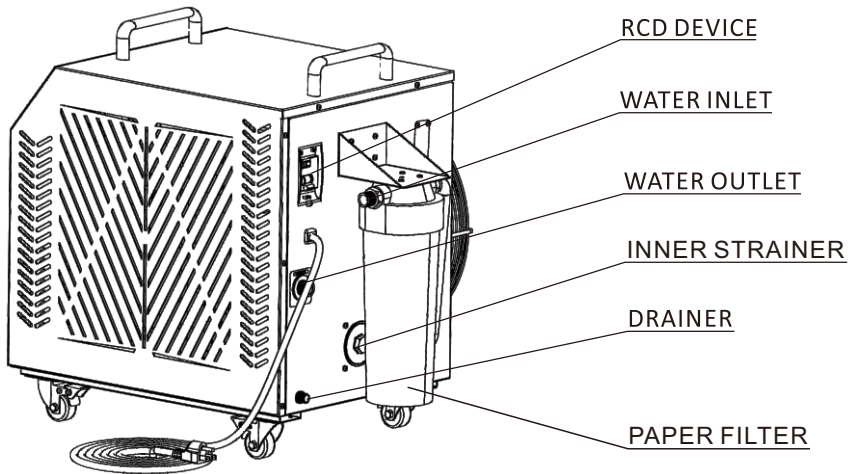
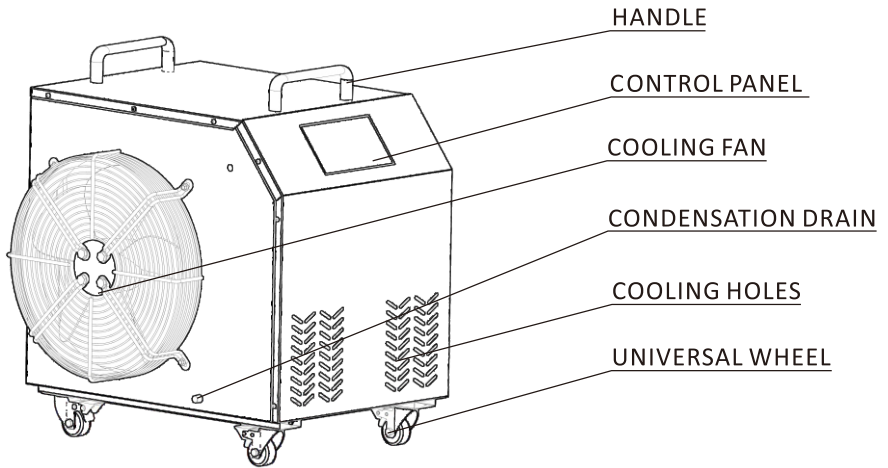

Filter & Strainer Wrench



Filter Elements
(Optional)



Water Pipes



Rubber O Rings

QUICK START GUIDE

1. Place the chiller on a **stable** surface near to your ice bath tub.
2. Connect both the **Inlet** and **Outlet** water pipes, and ensure the valves are 'hand tight'.

connect to the chiller

connect to the tub

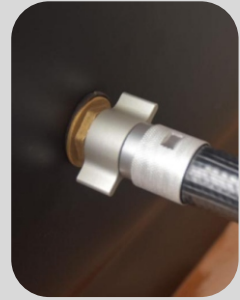

3. Fill the bathtub with enough water, the water level in the bathtub should be **higher** than the height of the chiller inlet.

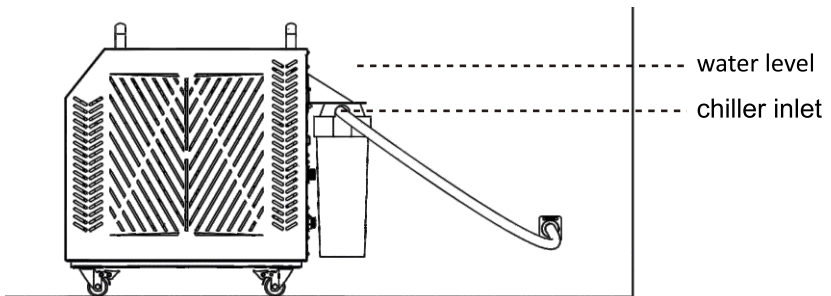

4. Ensure paper filter is installed and the cup is 'hand tight'.
5. Ensure the inner strainer is installed and the bottle is 'hand tight'.

QUICK START GUIDE

6. Plug in and switch on the chiller, the chiller will self-prime until its ready to use.



7. Once the chiller has finished its priming cycle it will start to chill and filter the water within a few minutes.

8. (Optional) Built-in ozone sterilization system automatically starts once in a while to disinfect the water.

9. Once the desired temperature is reached, **switch off** the chiller before starting your cold water therapy session.

*Tip:
Sometimes the air bubbles remain in the chiller would impact the water flow, opening the drainer until the water comes out can help pushing the bubbles out before turning on the chiller.*

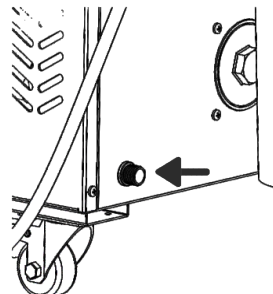

CONTROL PANEL INTRODUCTION

Status Icons



The corresponding icon will only light up when the current function is turned on

Long press ① to power on or off.

Long press ② to switch temperature units: Fahrenheit/Celsius.

Long press ③ to configure the network. The WIFI icon will blink during configuration, and the icon will remain steadily lit once network configuration is successful.

④ -Start temperature setting/confirm current temperature value.

⑤ -Move cursor up/increase temperature (long press for 5 seconds to activate heating mode, the heating icon will blink 5 times).

⑥ -Move the cursor down to decrease the temperature (long press for 10 seconds to restore factory settings; this button is disabled during power-up operation).

Automatic power-on when connected to electricity: Press button ② , then long press button ③ .

Activate ozone sterilization: Press button ③ ,then long press button ② .

Adjust the time using buttons ⑤ and ⑥ .

Remarks: Turn on/off child lock protection: Press buttons ⑤ and ⑥ simultaneously.

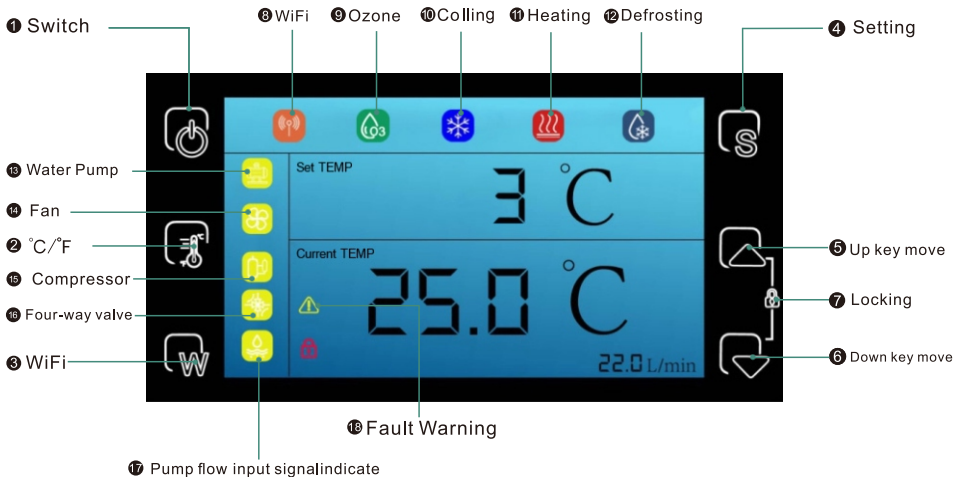

WIFI SETTINGS

1. Turn on the chiller.
2. Click the settings key.
3. Press WiFi key for 3-5 seconds until the WiFi blinks.
4. Open the Tuya Smart App on your phone.
5. Select add device.
6. Turn on your phone's WiFi connection and enter password.
7. Succeeded in adding a link, enter the App control panel.

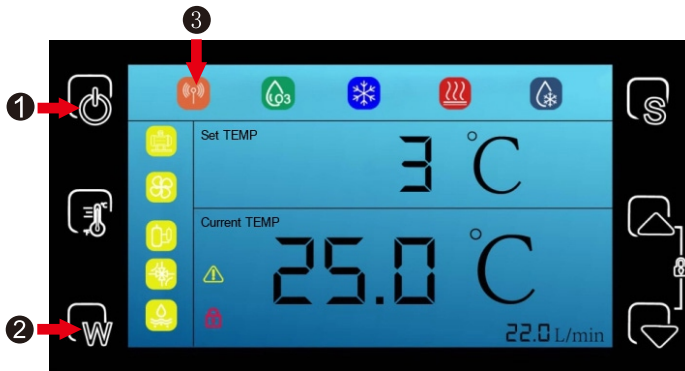

4



5

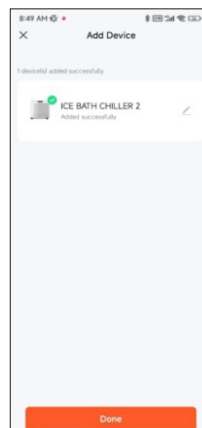

6

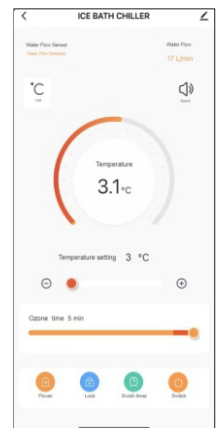

7

TUYA MOBILE APP PAIRING

At present, Tuya Smart can only support **2.4G** WiFi signal. Therefore, before connecting the phone to the chiller, please confirm that the Wifi used by your phone is in the **2.4G** frequency band. It will not be able to connect to the chiller if it is in the 5G band.



Tuya Smart

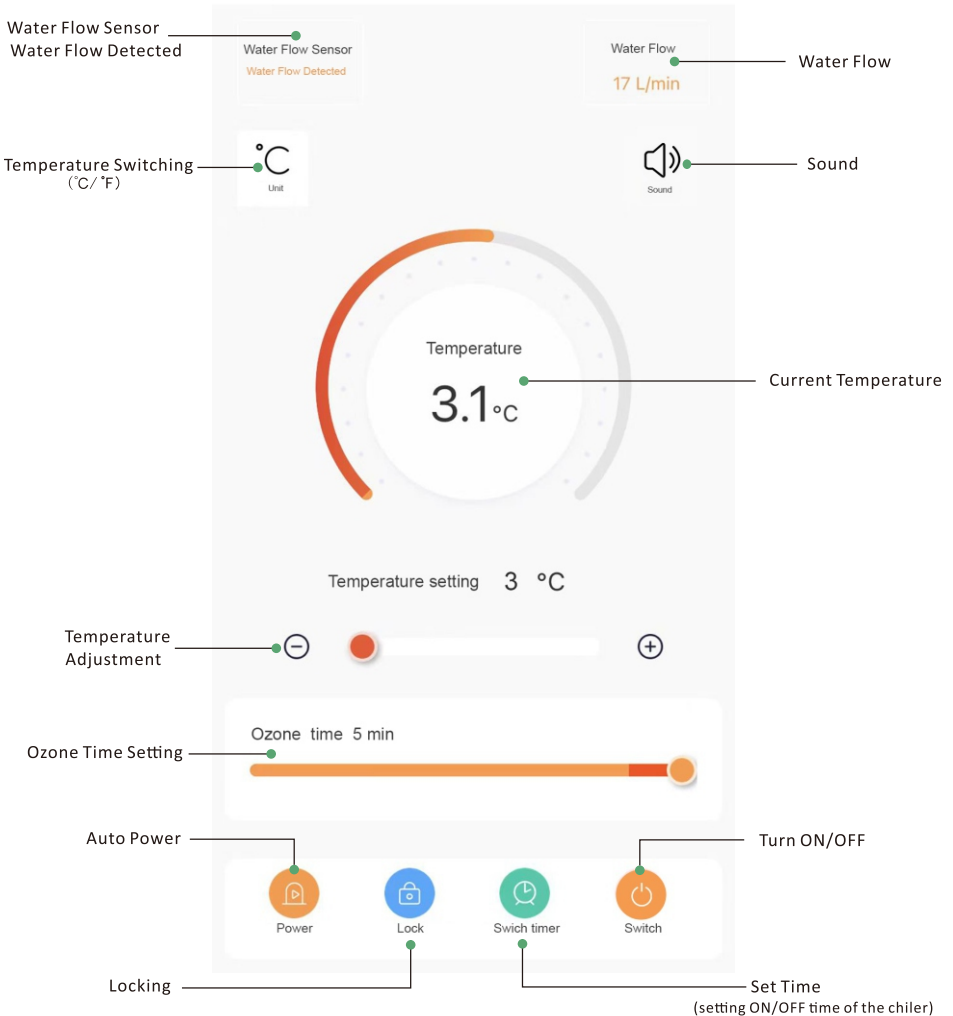

Please note: As these are 3rd party apps, we accept no responsibility for incompatibility or issues when using this with your chiller.

MAINTENANCE & CLEANING

1. Never put the chiller outside in temperatures below 1°C when it has water inside.
2. Never clean the chiller with strong bleach-based detergents.
3. Do NOT put corrosive disinfectants into the water, such as chlorine tablets.
4. ALWAYS disconnect it from the power supply before any maintenance or cleaning.
5. **Regularly** empty the chiller by opening the drainer at the rear of the unit and close it after use. To prevent **freezing** damage, make sure you empty your chiller before the ambient temperature gets 0°C (32°F).

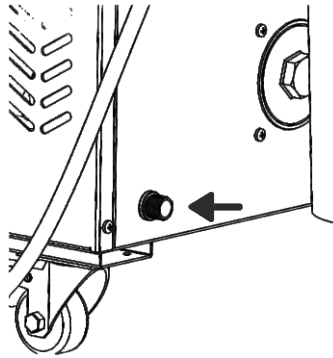

6. Replace the paper filter when it gets dirty to ensure a normal water flow rate and optimal performance.

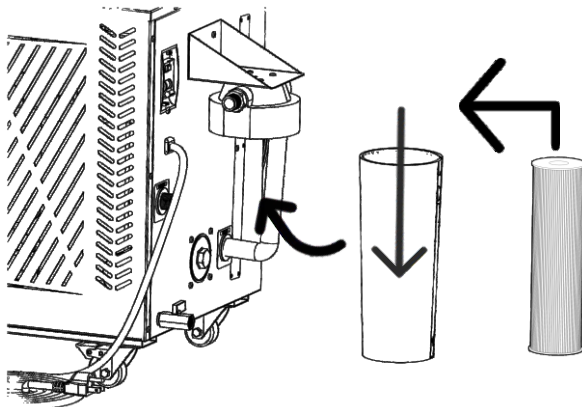

MAINTENANCE & CLEANING

7. Check and clean the inner strainer when the water flow rate gets lower. We recommend cleaning it every 4 weeks to ensure the water pump working perfect.

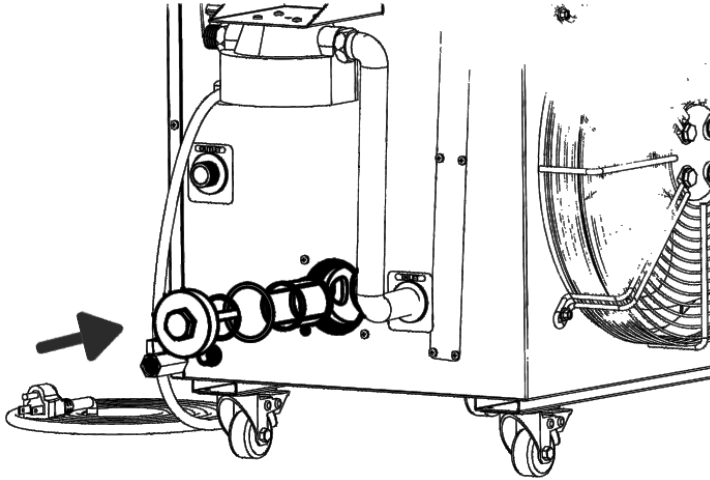

8. Check and clean the dust net when cooling/heating efficiency gets lower. We recommend cleaning it every 3 months to ensure the condenser working perfect.

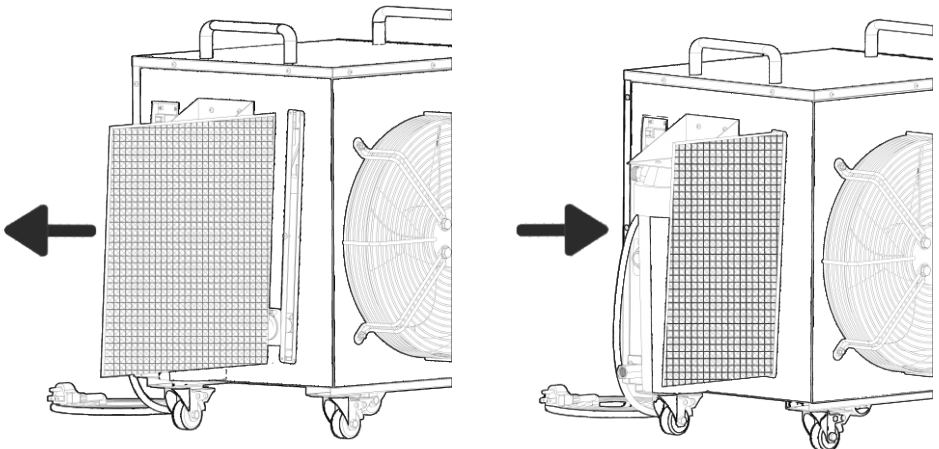

MAINTENANCE & CLEANING

9. Please do NOT place the device directly under the sun or in rain or snow; place the machine under a shelter.

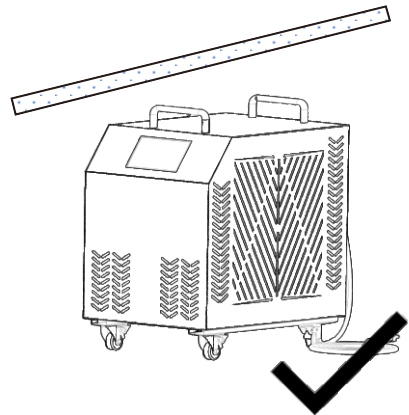
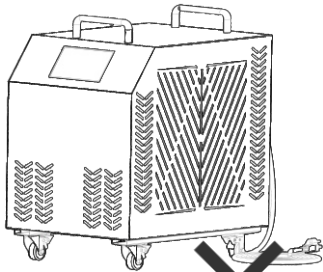

SPECIFICATIONS

Product Name	0.8HP		1HP		2HP	
Model No.	XY-08-HC XY-08-OC		XY-10-HC XY-10-OC		XY-20-HC XY-20-OC	
Power Supply	100-127V 60Hz	220-240V 50/60Hz	100-127V 60Hz	220-240V 50/60Hz	100-127V 60Hz	220-240V 50/60Hz
Input Power	725W	710W	1150W	1060W	1500W	1950W
Compressor Power	630W	605W	945W	900W	1260W	1660W
Cooling Capacity	2230W	2090W	2700W	2450W	3600W	5000W
Heating Function	2505W		3800W		4500W	5800W
Water Temperature	3° - 42°C adjustable					
Ozone Disinfection	Optional					
Circulation Pump	Yes					
Water filter	Yes					
Remote control	Yes					
Refrigerant	R410A					
Cooling Function	Yes					
Transport wheels	Yes					
Carry handle	Yes					
Quick Connectors	Yes					
Certification	CE					
Net Weight	29KG		35KG		45KG	
Product Dimension	56.2*43.5*52CM		62*42.4*55.6CM		69.2*44.3*60.5CM	